

# MYCHILL

## Product Manual

Installation, use and maintenance



**INDEX**

- 1. GENERAL INFORMATION ..... 4**
  - 1.1. Marking ..... 4
  - 1.2. Declaration of conformity ..... 5
  - 1.3. Warranty..... 6
  - 1.4. After-sales service ..... 6
  - 1.5. How to use and keep the manual ..... 6
    - 1.5.1. Symbols used in this manual..... 6
  - 1.6. Personnel description..... 7
- 2. MACHINE DESCRIPTION ..... 8**
  - 2.1. Description of blast chiller and its use..... 8
  - 2.2. Main parts ..... 8
  - 2.3. Noise..... 9
  - 2.4. Ambient conditions ..... 10
- 3. SAFETY ..... 11**
  - 3.1. General warnings..... 11
  - 3.2. Improper use ..... 12
  - 3.3. Safety devices..... 13
  - 3.4. Stop functions..... 15
- 4. TRANSPORT AND HANDLING ..... 16**
  - 4.1. Blast chiller transport..... 16
  - 4.2. Handling the packed blast chiller ..... 16
    - 4.2.1. Weight and dimensions..... 17
    - 4.2.2. Means required ..... 17
- 5. INSTALLATION ..... 18**
  - 5.1. Preparation for installation..... 18
  - 5.2. Unpacking..... 18
    - 5.2.1. Means required ..... 19
    - 5.2.2. Unpacking procedure..... 19
  - 5.3. Handling the blast chiller ..... 19
    - 5.3.1. Means required ..... 19
    - 5.3.2. Handling the unpacked blast chiller ..... 20
  - 5.4. Blast chiller assembly..... 20
- 6. SETTING UP ..... 21**
  - 6.1. Connections..... 21
    - 6.1.1. Electrical connection..... 21

6.2. Preliminary checks .....	22
6.2.1. Regulation .....	22
<b>7. USE.....</b>	<b>23</b>
7.1. Use foreseen.....	23
7.2. Unforeseen use.....	23
7.3. Residual risks .....	24
7.4. Control panel.....	24
7.5. Control procedures .....	26
7.6. Use procedures.....	26
7.7. Soft chilling .....	27
7.7.1. Selecting and setting of soft chilling cycle .....	27
7.8. Hard chilling .....	28
7.9. Freezing .....	29
7.9.1. Selecting and setting of freezing cycle .....	29
7.10. Special uses.....	29
7.10.1. Pre-chilling function or continuous cycle .....	29
7.10.2. Defrost .....	30
7.10.3. Long idle periods.....	30
<b>8. MAINTENANCE .....</b>	<b>31</b>
8.1. Special precautions.....	31
8.2. Routine maintenance.....	32
8.2.1. Routine maintenance table .....	32
8.2.2. Cleaning the chamber .....	32
8.2.3. Cleaning the outside of the appliance.....	33
8.2.4. Cleaning the condenser .....	34
8.2.5. Cleaning the core probe .....	35
8.3. Extraordinary maintenance.....	36
8.4. Operating anomalies and faults.....	37
8.4.1. Alarms.....	37
8.4.2. Errors.....	37
<b>9. DISMANTLING.....</b>	<b>38</b>
<b>10. DISPOSAL.....</b>	<b>39</b>
10.1. Disposal method .....	39
<b>11. SPARE PARTS .....</b>	<b>41</b>
11.1. Ordering spare parts.....	41

## 1. GENERAL INFORMATION

Thank you for choosing a blast chiller of our production.

Read this manual very carefully and make sure it is available to those who will install, use, and maintain the equipment.

### 1.1. Marking

The ID plates are located on the outside of the appliance, in the bottom right-hand corner of the front: Fig. 1 below shows copies.

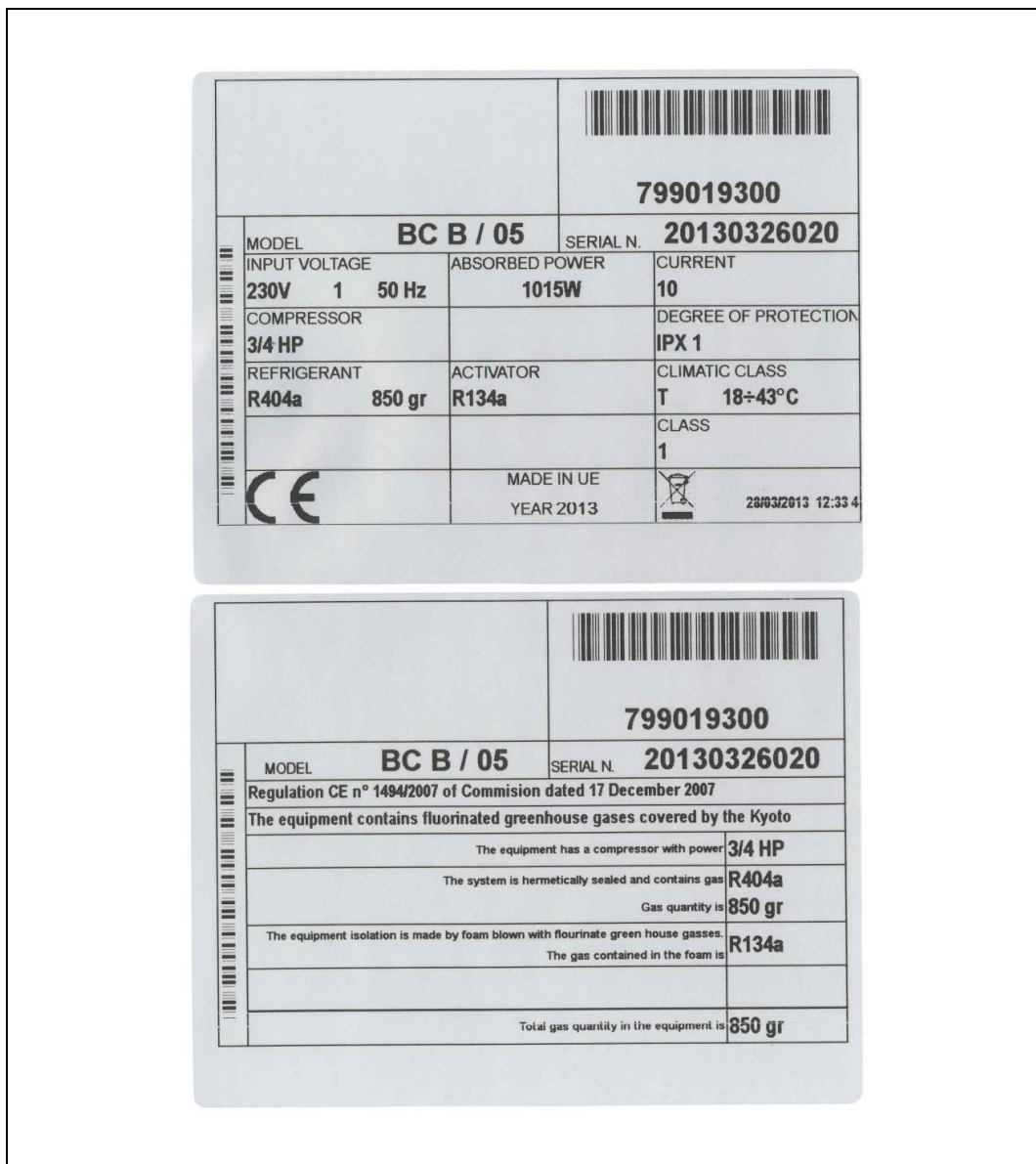

Figure 1. ID plates

## 1.2. Declaration of conformity

# mychef.

## Declaration of Conformity CE

Manufacturer: DISTFORM, S.L.  
Address: C. Tramontana, s/n, 25123 Torrefarrera, Lleida, Spain  
Product: Blast chillers Mychill  
Models: TCHA03TG, TCHA05LG, TCHA05TG, TCHA10TG, TCHA15TG

We declare under our responsibility that the mentioned products comply with the following EU directives:  
Directive 2014/30 CE relating to electromagnetic compatibility  
Directive 2014/35 CE relating to electrical equipment of low voltage  
Directive 2006/42 CE relating to machinery

In addition, the mentioned products meet the following norms:  
EN 55014-1:2017/A11:2021  
EN 55014-2:2015  
EN 61000-3-2:2014  
EN 61000-3-3:2013/A1 :2020  
EN 61000-3-11:2020  
EN 61000-3-12:2012  
EN 61000-6-2:2006 ERRATUM 2009  
EN 61000-6-3:2007/A1:2012  
EN 60335-1:2012/A1:2020  
EN 60335-2-64 CORR:2003  
EN 60335-2-42:2004 CORR:2007  
EN 62233:2009  
EN 55014-1:2017/A11:2021  
EN 55014-2:2015

Lleida, 7th January 2020

CE

  
Albert Torne  
R & D Director

mychefcooking.comDECLARATION OF CONFORMITY CE MYCHILL - DT.CE.MC210421

Figure 2. Declaration of conformity

### 1.3. Warranty

The warranty covering the various parts of the appliance is valid from the date on the relative delivery note and is as described in the sales agreement.

The warranty does not cover damage to the appliance caused by:

- transport and/or handling;
- operator errors;
- lack of the maintenance described in this manual;
- faults and/or breakages that cannot be traced to faulty operation of the appliance;
- maintenance operations carried out by unqualified personnel;
- improper use.

### 1.4. After-sales service

Please contact the manufacturer directly for any needs regarding use, maintenance or ordering of spare parts, and specify the identification of the appliance given on the ID plate.

### 1.5. How to use and keep the manual

The purpose of this manual is to provide all the information necessary to ensure proper use of the appliance in complete safety and independence.

The manual is sub-divided into chapters with paragraphs and sub-paragraphs: the contents page is easily consulted to find any aspect of interest.

The material in this document is provided exclusively for the purpose of information and may be altered without notice. Although great attention is paid to drawing up the manual, **the manufacturer is not responsible for damage deriving from errors, omissions or the use made of the information herein.**

Keep this manual and all the documentation in the appendices in good condition, legible and complete in all its parts; keep it close to the equipment in an accessible place known to all operators.

#### 1.5.1. Symbols used in this manual



***This symbol indicates information and warnings which if not observed could damage the appliance or compromise the safety of personnel.***



***This symbol indicates information and warnings regarding electrical devices which if not observed could damage the appliance or compromise the safety of personnel.***

## 1.6. Personnel description

The manual is intended for both the operator and the technicians authorized to install and maintain the appliance.



***Operators must not carry out operations reserved for maintenance engineers or specialized technicians.***

***The manufacturer accepts no responsibility for damage deriving from failure to observe this rule.***

- **Appliance operator:** specialised person who can operate the appliance in normal working conditions by using the relevant controls. The operator must also be capable of carrying out simple routine maintenance (cleaning, loading) and starting or resetting the appliance after a power failure.
- **Specialised electrician:** specialised electrician who has been trained by the manufacturer to work on the appliance. The specialised electrician must be capable of installing the appliance and operating it in normal conditions; s/he is qualified to carry out all electrical and mechanical adjustments, maintenance and repairs. S/he is able to operate with live electrical control boxes and connector blocks.
- **Qualified fork-lift operator:** person qualified in handling materials on the company's premises, holder of a license for the use of fork-lift trucks.

## **2. MACHINE DESCRIPTION**

### **2.1. Description of blast chiller and its use**

Blast chillers are appliances with a powerful refrigeration system that can rapidly reduce the temperature at the core of food. Ideal for use in kitchens, bakeries, and ice cream establishments.

The machine's main work cycles are CHILLING and FREEZING. Each cycle includes two different end of cycle modes at the point at which holding commences: temperature controlled (the probe inserted into the core of the product ends the cycle when it reaches the set temperature) or time controlled (the cycle ends as soon as the set time expires).

### **2.2. Main parts**

The appliance comprises the following parts:

- body;
- condenser unit (ref. 2, fig. 3);
- evaporator unit (ref. 1, fig. 3);
- control panel (ref. 3, fig. 3)



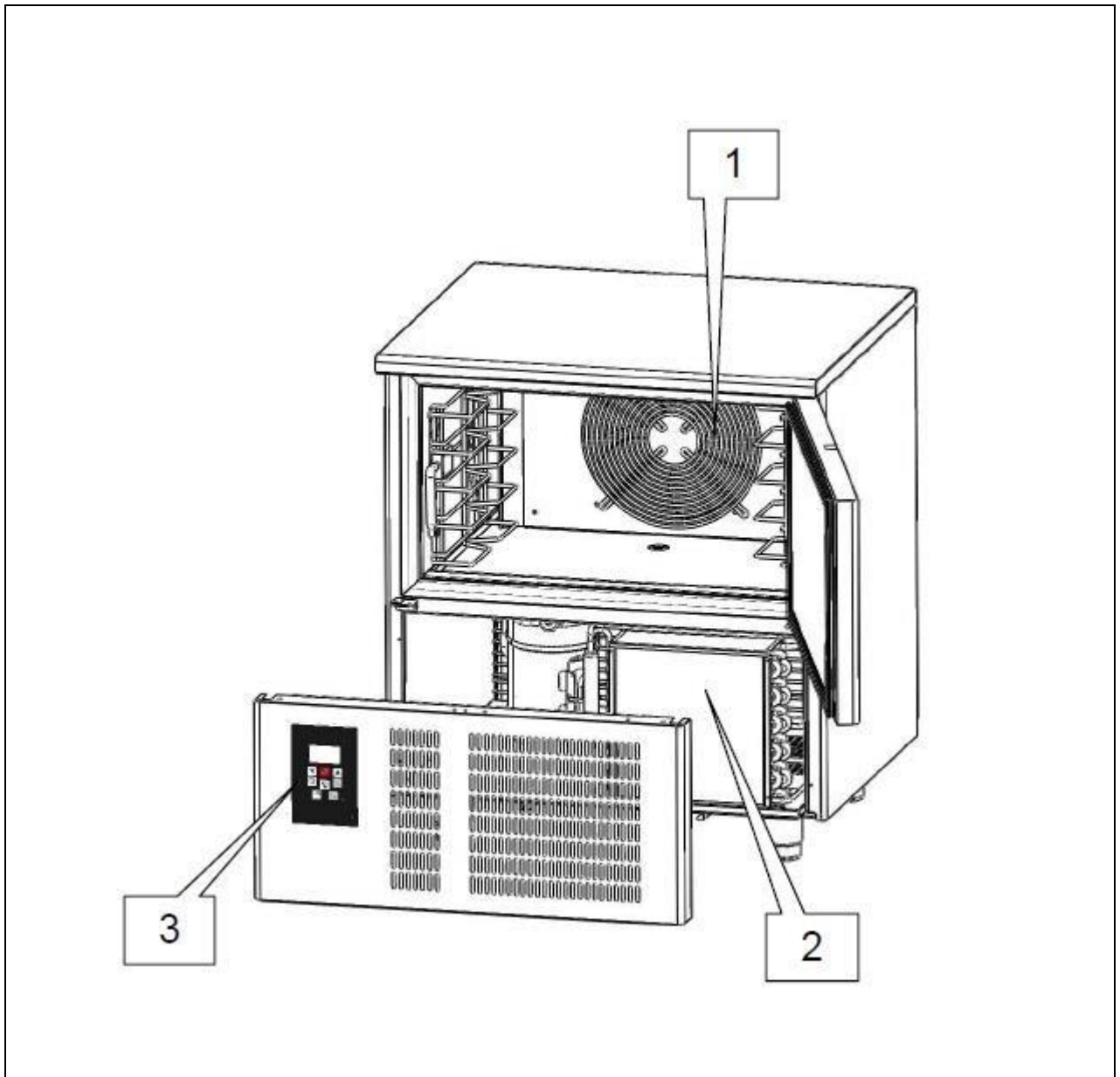

**Figure 3. Mychill blast chiller parts**

### **2.3. Noise**

The appliance is designed and built to keep its noise level as low as possible.

## 2.4. Ambient conditions

<b>Installation site</b>	Bakeries, confectioner's, ice cream makers, and kitchens in general
<b>Relative humidity</b>	$\leq 80\%$ without condensation
<b>Climatic class</b>	"T" + 18 °C ÷ + 43 °C

**Table 1. Ambient conditions for Mychill blast chiller**

### 3. SAFETY

#### 3.1. General warnings



**IMPORTANT:** before using the appliance read this manual carefully and follow the technical operating instructions and indications to the letter. The operator must know the position and function of all the control devices and the characteristics of the blast chiller.

*The blast chiller complies with current safety regulations, but improper use may cause damage to persons and things.*



*At the time of installation all operatives must be suitably trained in accident hazards, operator safety devices, general accident prevention regulations described in international directives and the current law in the countries where the appliance is used. Start-up and use of the appliance must be exclusively in the hands of trained personnel. The behaviour of operators must in any case scrupulously observe accident prevention regulations in the country where the appliance is used.*



*Do not remove or deface the plates fitted to the appliance by the manufacturer.*



*The blast chiller must not be used if the control panel or any other part is damaged.*



*Do not obstruct the front and/or rear air vents on the appliance; do not place food to be processed up against the ventilation grilles or air ducts, or directly on the bottom of the chamber.*



*Promptly report any anomalies in operation.*



*Use only accessories recommended by the manufacturer.*



*Do not expose the appliance to rain or sprays of water.*



*Routine and extraordinary maintenance that require the electrical box to be opened or even partial dismantling of the blast chiller must be carried out only after the appliance has been disconnected.*

The manufacturer has no responsibility in the following cases:

- the maintenance plan is not carried out
- unauthorized alterations and/or operations
- spare parts used are not original
- failure to observe even part of the contents of this manual
- improper use of the appliance.

Any tampering with or unauthorized replacement of one or more appliance parts or components and use of accessories and consumables different from the original ones can constitute a hazard and relieve the manufacturer of any civil or penal responsibility.

If in doubt about operation of the appliance, refrain from using it and contact the manufacturer.

### **3.2. Improper use**

The blast chiller must not be used:

- for purposes different from those given in paragraph 2.1 "Description of blast chiller and its use";
- with safety systems not working;
- after badly done installation;
- by untrained personnel;
- when maintenance has not been carried out, or has been carried out badly;
- when non-original spare parts are used;
- with damaged power lead and/or electrical socket;
- with obstructed air ducts (ref. 1 fig. 4);
- with the food to be processed placed against the ventilation grilles (ref. 1 fig. 4), air ducts, or on the bottom of the chamber (ref. 2 fig. 4).

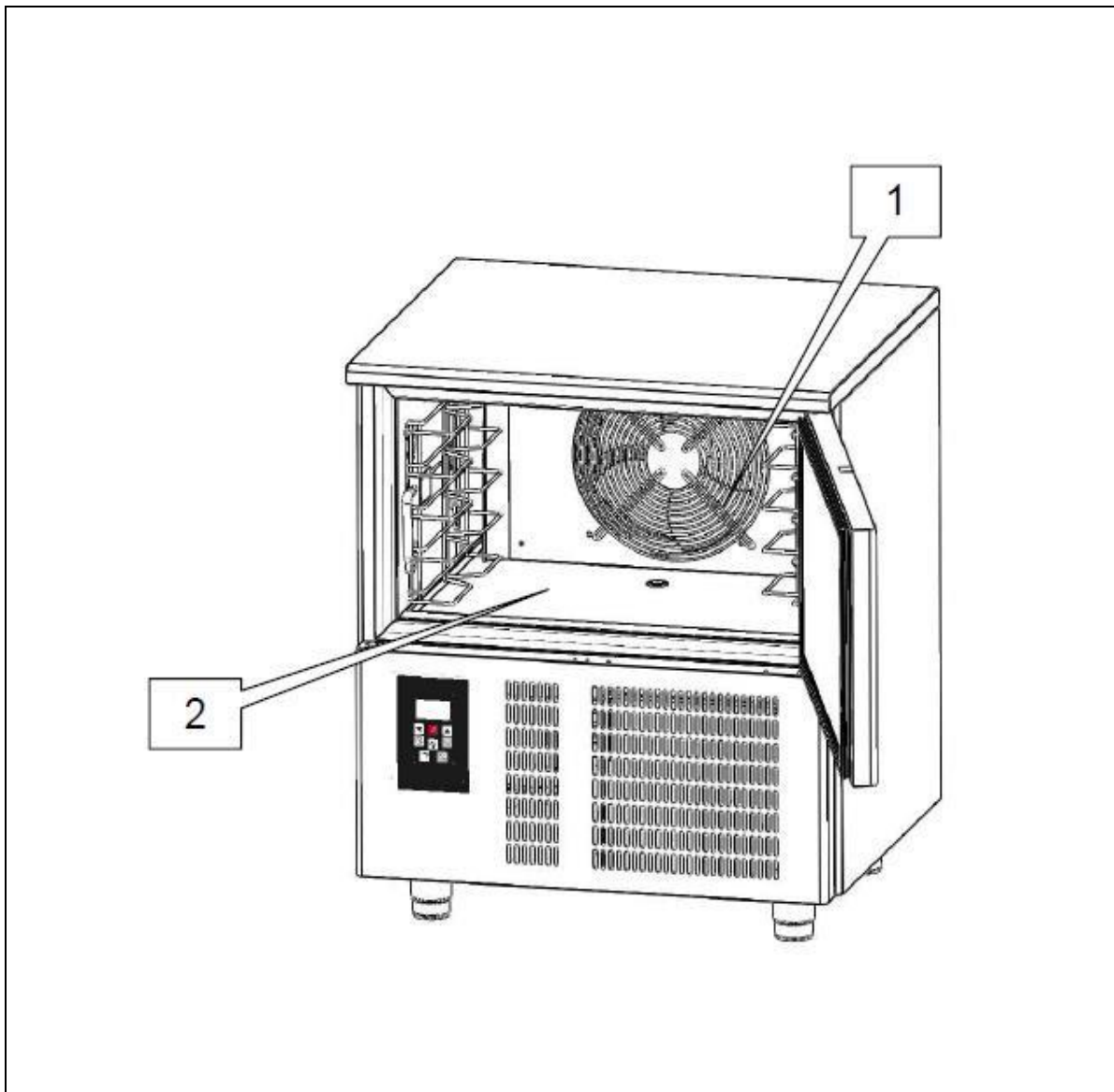

**Figure 4. Air ducts and ventilation grilles**

### **3.3. Safety devices**

Personnel exposed to the hazards inherent in moving parts are protected by special safety devices on the appliance:

- grilles covering the cooling fans (ref. 1 fig. 5);
- grilles covering the condenser unit (ref. 2 fig. 5).

The appliance is also provided with devices to protect the food during processing. Below is a list of the safety devices on the appliance:

- Sensor reads and signals door opening. If the doors remains open for a presetted time, it will appear on the display the message " id " combined with an acoustic alarm and the compressor will switch off.

- Sensor (ref. 3 fig. 5) located on cooling circuit signals any overheating of the equipment and places the machine on standby.

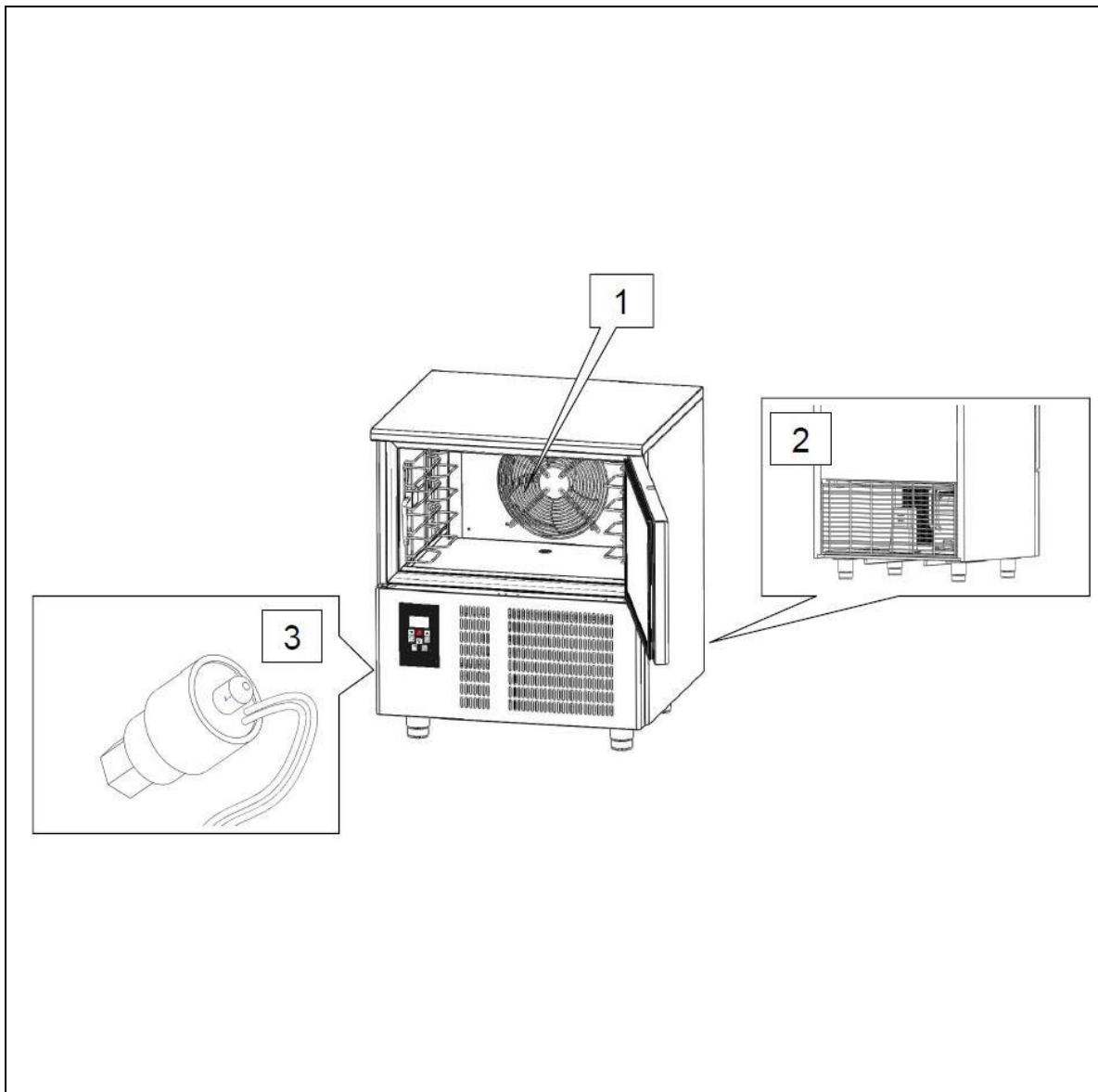

**Figure 5. Mychill blast chiller grilles and sensor**

### 3.4. Stop functions

The entire appliance is controlled by an electronic circuit board. The stop function is represented by the button START/STOP (ref. 1 fig. 6). Whatever condition the machine is in, holding down the button START/STOP for 3 seconds cuts out the circuit board.

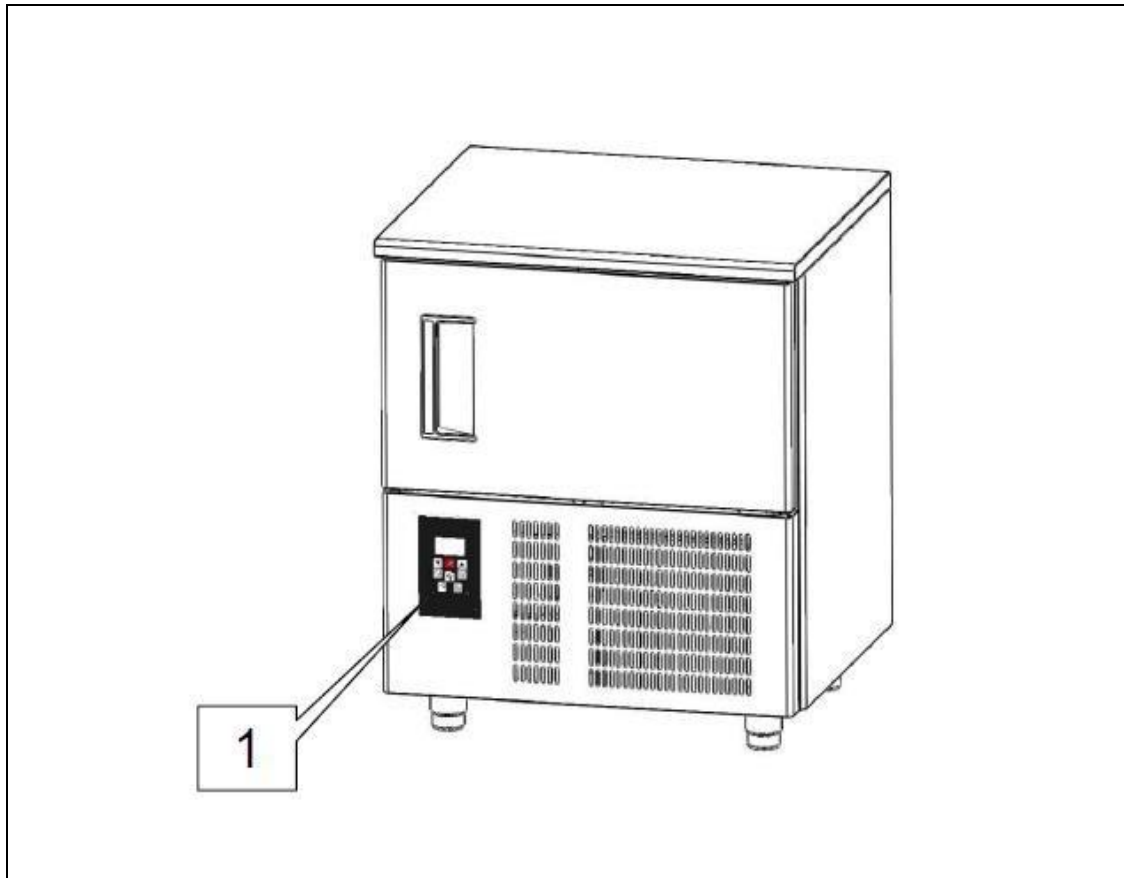

**Figure 6. START/STOP button**

## 4. TRANSPORT AND HANDLING

### 4.1. Blast chiller transport

The packing used is suitable for the type, dimensions and weight of the appliance and ensures that it is protected and remains undamaged during transport and delivery to the purchaser.

The blast chiller must be placed in position and kept upright on a pallet and surrounded by its packing box throughout its journey.

The blast chiller is handed over to the carrier ready to be handled.



***The appliance must never be overturned.***



***The packing must be well placed on the platform of the means of transport and secured by appropriate ropes.***



***Take the utmost care when lifting and positioning the blast chiller, so as to avoid serious damage to persons or things. The manufacturer declines all responsibility if the indications for lifting and transport the blast chiller are not observed.***



***Ambient temperature must never drop below 4°C during transport.***

Once the blast chiller has been unpacked, the packing material must be eliminated and/or re-used in compliance with current waste disposal regulations in the countries where the appliance will be used.

### 4.2. Handling the packed blast chiller



***Take great care when lifting and handling the blast chiller; there is an injury hazard in handling loads, which may also be fatal.***



***All handling and lifting operations must be carried out with great caution, making sure that all personnel is strictly at a safety distance and that no-one stands under suspended loads, be they still or in motion.***



***Before starting the operation, check the whole appliance handling area to identify any dangerous points.***





**Ambient temperature must never drop below 4°C during transport.**

#### **Authorized personnel:**

Specialised fork-lift truck operator.

#### **Individual safety devices:**

- safety shoes
- safety gloves

Personnel carrying out such operations must not wear rings, wrist watches, jewellery, loosed or unfastened garments, such as, for example, ties, torn garments, scarves, unbuttoned jackets, or blouses with open zips, etc. In general, personnel must wear safety apparel.

#### **4.2.1. Weight and dimensions**

<b>Model</b>		<b>BCB/03</b>	<b>BCB/05</b>	<b>BCB/10</b>	<b>BCB/15</b>	<b>BCB/24</b>
<b>Dimensions</b>	cm	65x65x67h	80x70x90h	80x78x170h	80x78x200h	80x118x200h
<b>Weight</b>	kg	76	107	166	202	230

**Table 2. Blast chiller weight and dimensions**

#### **4.2.2. Means required**

Para el levantamiento del aparato se debe utilizar una carretilla con capacidad mínima adecuada.



***The use of unsuitable equipment can cause accidents to those involved in the operation and/or damage to the appliance.***



***The manufacturer declines all responsibility for improper non-compliant use of equipment for lifting, transport and handling.***

## 5. INSTALLATION



***Use the utmost care in handling the appliance, so as to avoid damage to persons or things.***



***Do not start the appliance if there are faults on the control panel or parts are damaged.***

### **Authorized personnel:**

Specialised electrician.

### **Individual safety devices:**

- safety shoes
- safety gloves

Personnel carrying out such operations must not wear rings, wrist watches, jewellery, loosed or unfastened garments, such as, for example, ties, torn garments, scarves, unbuttoned jackets or blouses with open zips, etc. In general, personnel must wear safety apparel.

### **5.1. Preparation for installation**

For installation prepare an area of manoeuvre suitable for the dimensions of the appliance (see fig. 2) and the chosen lifting equipment.

The installation site must be prepared with all the connecting systems required for the appliance to work.

Choose an installation site with requisites that will allow the appliance to be used safely. The area must provide good support, with a solid flat floor whose finish will ensure a suitable and safe working place for personnel.

Install the appliance in a place with natural and/or artificial light suitable for the operations to be carried out (in compliance with specific regulations).

### **5.2. Unpacking**



***Check that the packing has not been damaged during transport.***

### 5.2.1. Means required

Use a fork-lift truck or equivalent equipment to lift the appliance.



***The use of unsuitable equipment can cause accidents to those involved in the operation and/or damage to the appliance.***



***The manufacturer declines all responsibility for improper non-compliant use of equipment for lifting, transport and handling.***

### 5.2.2. Unpacking procedure



***All the handling and unpacking operations must be carried out with extreme care, making sure that all personnel is strictly at a safety distance and that no-one stands under suspended loads, be they still or in motion.***

To unpack the appliance just remove its cardboard wrapping. Take the appliance off the pallet, lifting it by means of a suitable fork-lift truck; the forks should be placed under the appliance **taking care not to damage the two water tray guides.**



***AFTER INSTALLING THE APPLIANCE, WAIT AT LEAST TWO HOURS BEFORE TURNING IT ON.***

## 5.3. Handling the blast chiller

### 5.3.1. Means required

See section 5.2.1.



***The use of unsuitable equipment can cause accidents to those involved in the operation and/or damage to the appliance.***



***The manufacturer declines all responsibility for improper non-compliant use of equipment for lifting, transport and handling.***

### 5.3.2. Handling the unpacked blast chiller



***All the handling and unpacking operations must be carried out with extreme care, making sure that all personnel is strictly at a safety distance and that no-one stands under suspended loads, be they still or in motion.***

To move blast chillers on wheels, release the brakes on the wheels and push, taking care to block the brakes again when the appliance is in its permanent position.

To move blast chillers on feet, lift them with a suitable fork-lift truck; the forks should be placed under the appliance, **taking care not to damage the two water tray guides.**

### 5.4. Blast chiller assembly

The blast chiller is delivered to the customer assembled in all its parts.

Remove the water tray from the chamber and place it in position along the guides placed under the appliance between the feet.

## 6. SETTING UP



**AFTER INSTALLING THE APPLIANCE, WAIT AT LEAST TWO HOURS BEFORE TURNING IT ON.**

### 6.1. Connections

#### 6.1.1. Electrical connection



**Electrical connection must be made by a specialised electrician.**

- Check that the power supply voltage given on the ID plate corresponds to that available at the installation site.
- Connections must be made to current regulations; the supply mains must have an efficient earthing system compliant with electricity regulations in the country; this is a responsibility of the customer.
- Do not make tight bends on the power lead and do not place any object whatsoever on top of it.



**If it is necessary to unplug the mains supply, first make sure the circuit board is on OFF on the display.**



**The manufacture declines all responsibility for damage or accidents caused by failure to observe such regulations.**

#### Electrical connection procedure

The appliance is supplied by the manufacturer complete with power plug. Just connect the power plug to a socket at the installation site; the system must be carried out to current regulations.

The electricity supply at the installation site must have the following requisites:

- Voltage: 230 Vac
- Frequency: 50 Hz

## 6.2. Preliminary checks

The electrician fitter shall train the operator in the correct use of the blast chiller and give the basic notions of maintenance.

### Method

The operations to prepare the blast chiller for initial start-up must be carried out by a specialised engineer, in the presence of the operator in charge of the use of the appliance, who can acquire information to carry out certain routine maintenance and cleaning.

Before starting up the appliance, a series of checks and inspections must be carried out for the purpose of preventing errors or accidents during start-up.

- Check that the appliance has not been damaged during transport.
- Check with special care for any damage to the electrical box, push button control panel, wiring and pipes.
- Check that all external power sources have been connected properly.
- Check that the machine is perfectly level.

### 6.2.1. Regulation



***Regulation carried out by unauthorized personnel may damage the appliance and expose the operator to serious hazards. Regulation carried out by unauthorized personnel is considered tampering with the appliance and as such null the warranty and relieve the manufacturer of any responsibility.***

## 7. USE



**AFTER INSTALLING THE APPLIANCE, WAIT AT LEAST TWO HOURS BEFORE TURNING IT ON.**

### 7.1. Use foreseen

Blast chillers are appliances with a powerful refrigeration system that can rapidly reduce the temperature at the core of food. Ideal for use in kitchens, bakeries and ice cream establishments.

The machine's main work cycles are CHILLING and FREEZING. Each cycle includes two different end of cycle modes at the point at which holding commences: temperature controlled (the probe inserted into the core of the product ends the cycle when it reaches the set temperature) or time controlled (the cycle ends as soon as the set time expires).

- **SOFT CHILLING.** Positive "delicate" temperature reduction (+3°C). Food just out of the oven is quickly taken to a temperature of 3°C in no longer than 90', thus inhibiting bacterial proliferation and avoiding dehydration of the cooked food due to evaporation. Food treated in this way can be preserved perfectly for 5-7 days without altering its original qualities.
- **HARD CHILLING.** Positive "rapid" temperature reduction (+3°C). Also lasts for a maximum of 90'. This type of process is used when the food to be chilled is thicker than 2-3 centimetres (i.e. large joints) and with dense or food. The appliance develops variable air temperatures to accelerate penetration of the cold into the food.
- **FREEZING.** Deep freezing or freezing (-18°C). This work cycle will take the core of the food to a temperature of -18°C in less than four hours (240'). The speed of the process avoids the formation of macrocrystals, ensuring that when it is used the thawed food has its original consistency, colour and quality.
- **HOLDING.** At the end of both the chilling and freezing cycles the machine will automatically go to the set holding temperature.

### 7.2. Unforeseen use

Blast chillers cannot be used for purposes other than those described in point 7.1. particular the blast chiller is not suitable for storing food for an indefinite period.

### 7.3. Residual risks



**LOW TEMPERATURE BURN HAZARD.**

**During its operation the appliance runs extremely low temperatures: avoid direct contact with the internal parts immediately after opening the door.**



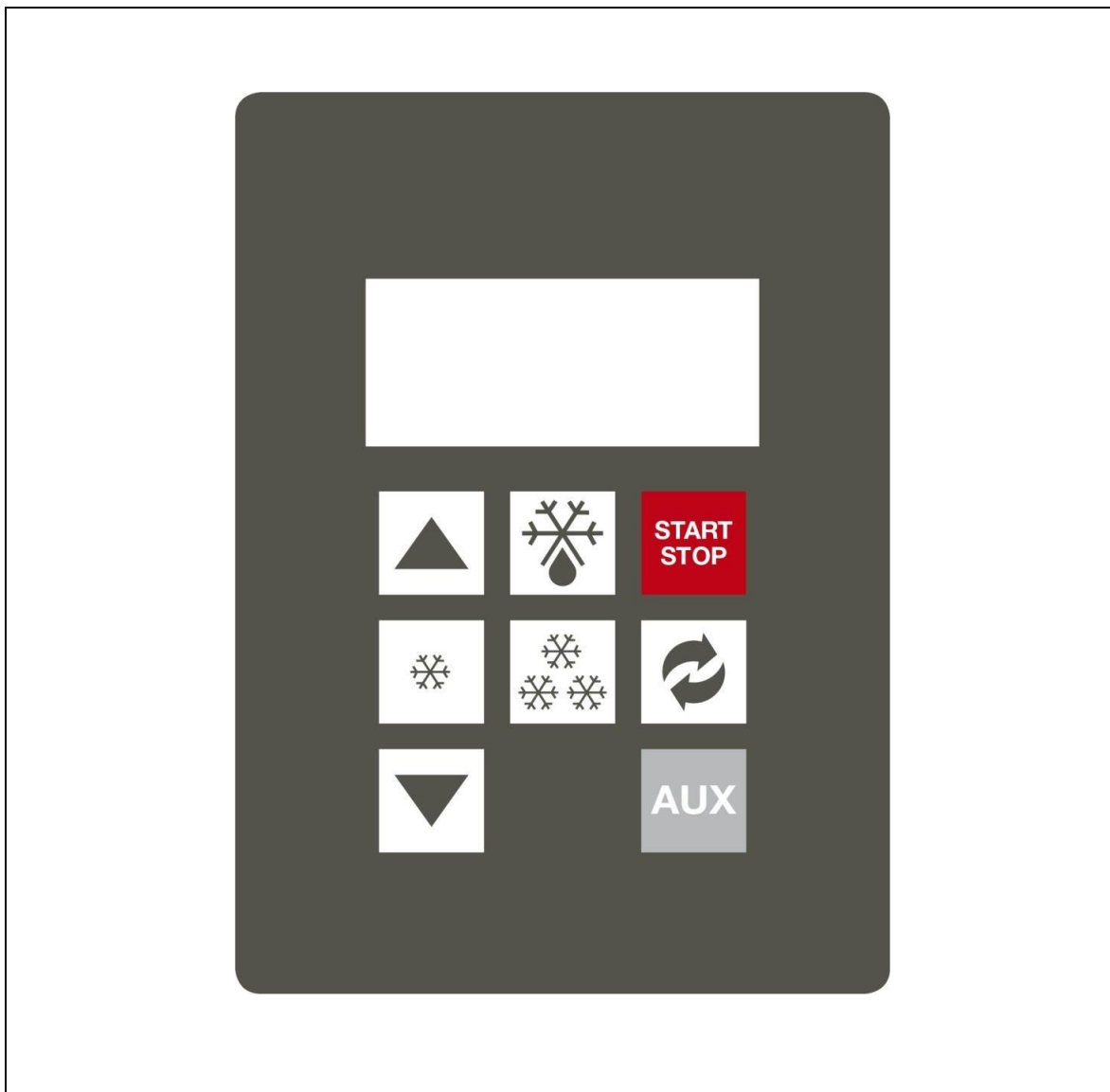



### 7.4. Control panel





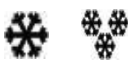



**Figure 7. Mychill blast chiller control panel**



Los botones presentes en el controlador son:

	BUTTON 0/1, START/STOP	With the machine OFF (0) press once to go to STANDBY (1). With the machine on STANDBY press once to START a cycle. When a cycle is in progress press once to STOP it. In whatever situation the machine is, if the button is held down for 3 seconds the circuit board is cut OFF.
	+ AND - BUTTONS	Used to increase or decrease the value shown on the display.
	DEFROST BUTTON	With the machine on STANDBY and/or during the storage, press once to start a defrost cycle.
	CHILLING BUTTON	With the machine on STANDBY press once to select a chilling cycle. Keep held down the button for 3 second in order to start the continuous cycle.
	HARD/SOFT BUTTON	With the cycle selected, press once in order to select HARD or SOFT process.
	FREEZING BUTTON	With the machine on STANDBY press once to select a freezing cycle.
	AUXILIARY BUTTON	Press this button in order to use the accessory, as UV lamp, warmed probe, where installed.



The icons on the control panel display are:

	OFF	Illuminated when the machine is OFF; not illuminated in all other situations.
	CELSIUS	Can be illuminated in red or green to indicate the temperature measuring unit.
	CHILLING AND FREEZING	Flash when the cycles they refer to are in progress; remain illuminated during the following holding cycle.
	TEMPERATURE	Illuminated during a temperature-controlled cycle.
	TIME	Illuminated during a time-controlled cycle.
	HOLDING	Illuminated or flashing during the holding period.
	CONTINUOUS CYCLE	Illuminated or flashing during the pre-cooling phase, also CONTINUOUS CYCLE.

## 7.5. Control procedures

The entire appliance is controlled by an electronic circuit board.

When the machine is powered the appliance, display illuminates fully for a “lamp-test” lasting a few seconds, at the end of which it returns to the condition it was in before being switched off. In particular, if a cycle was in progress, it will re-start from the point at which it was interrupted.

With the circuit board OFF the display is completely off, except for the  icon. Press the START/STOP button to turn off the  icon on the display and go to STANDBY, which shows the chamber temperature in blue.

The various machine functions can be activated by using the controls on the panel and observing the indications on the display.

With the circuit board in STANDBY, you can go from one cycle to another simply by pressing CHILLING and FREEZING button.

With the circuit board on STANDBY and a cycle selected you can start the cycle by pressing START/STOP (START).

Pressing START/STOP (STOP) once blocks the cycle in progress.

The buzzer can be silenced, whatever its cause, by pressing any button.

Whatever situation the machine is in, holding down for 3 seconds the START/STOP button cuts OFF the circuit board.

## 7.6. Use procedures

Clean the inside of the chamber before using the machine.

After installation or a prolonged idle period, it is good practice to operate the empty appliance until it reaches the set temperature.

To achieve good output from the blast chiller it is advisable to place the food inside in such a way as to assist air circulation: do not obstruct the fan, do not stack trays on top of each other, distribute the load neatly and do not cover the containers with lids or cling film.

In order to avoid altering the food, it is also advisable not to overload the machine beyond the permitted load, not to use pieces thicker than 50-70mm. and to limit door opening as much as possible.

Clean and sterilise the core probe before use. The probe must be placed in the centre of the largest joint or piece, taking care that the point does not go right through the food to come into contact with the tray.

**To improve the efficacy of the working cycle is recommended to perform a pre-cooling of the cell, by turning on the machine at least 15 min before insert the product, both in chilling and freezing.**





**When a cycle is selected the electronic circuit board checks the temperature read by the chamber probe and core probe to assess correct insertion of the probe (AUTOMATIC probe identification). This check lasts just over two minutes, at the end of which the cycle proceeds normally if the probe is properly inserted. This check lasts just over 2 minutes, accordingly with established parameters, at the end of which the cycle proceeds with a temperature-controlled cycle if the probe is properly inserted. In this case the temperature of the probe will be showed and the icon  will remain turned on.**



**If the test has a negative result, after a minute of buzzer's alarm, the display will show the icon  and the cycle will proceed with a time-controlled cycle.**

## 7.7. Soft chilling

### 7.7.1. Selecting and setting of soft chilling cycle





Load the machine suitably with the food to be chilled, place the core probe into the food and close the door.

With the appliance on STANDBY press  : the display will show the set point temperature of the room referred to **-5°C** cycle, in the meantime the icons  and  flash. Use the  and  buttons to edit this value.

Press START/STOP (START) to start the cycle: the display will show the temperature of the room and the icons  and  will remain on. As already explained, once confirmed the cycle, the device does an automatic identification of probe's insertion (around 2 minutes), at the end of which the cycle will be confirmed or by probe or by time. All this process will be made AUTOMATICALLY.

If the test has a positive result, the device will confirm the temperature controller cycle (probe) and the display will show the temperature of the probe.

Otherwise, if the result is negative, after buzzer's alarm and visual signalling of the flashing icon , the display will show the icon  and the cycle will change in time controlled cycle. Use the  and  buttons to edit this value.

During the visualization of the residual time, it is possible to change the temperature of the room by pressing the buttons     .

It is possible select the time-controlled cycle **DIRECTLY**, bypassing the automatic phase of probe's recognizing.

With the appliance on STANDBY press **TWICE**  : the display will show the duration of the cycle **90 min**, in the meantime the icons  and  flash. Use the  and  buttons to edit this value. Then press START/STOP in order to start the cycle.

Once finish the time relative to 90' cycle or once reaches the core temperature of +3°C, the device automatically starts the conservation cycle, +2°C rooms, previously reported by the buzzer's alarm.





On the display will appear the icon .

The cycle can be interrupted at any time by pressing START/STOP (STOP): press START/STOP (START) again in order to restart again the cycle.



## 7.8. Hard chilling

### 7.8.1. Selecting and setting of hard chilling cycle





Load the machine suitably with the food to be chilled, place the core probe into the food and close the door.



With the appliance on STANDBY press  : the display will show the set point temperature of the room referred to **-5°C** cycle, in the meantime the icons  and  flash. Use the  and  buttons to edit this value.

Press once the  button in order to start with hard phase. Also, the symbol HARD will flash on the display.

Press START/STOP (START) to start the cycle: the display will show the temperature of the room and the icons  and  will remain on. As already explained, once confirmed the cycle, the device does an automatic identification of probe's insertion (around 2 minutes), at the end of which the cycle will be confirmed or by probe or by time. All this process will be made AUTOMATICALLY.

If the test has a positive result, the device will confirm the temperature controller cycle (probe) and the display will show the temperature of the probe.

Otherwise, if the result is negative, after buzzer's alarm and visual signalling of the flashing icon , the display will show the icon  and the cycle will change in time controlled cycle. Use the  and  buttons to edit this value.

During the visualization of the residual time, it is possible to change the temperature of the room by pressing the buttons , , .

It is possible select the time-controlled cycle **DIRECTLY**, bypassing the automatic phase of probe's recognizing.

With the appliance on STANDBY press TWICE  : the display will show the duration of the cycle **90 min**, in the meantime the icons  and  flash. Use the  and  buttons to edit this value. Then press START/STOP (START) in order to start the cycle.

Once finish the time relative to 90' cycle or once reaches the core temperature of +3°C, the device automatically starts the conservation cycle, +2°C rooms, previously reported by the buzzer's alarm.







On the display will appear the icon .



The cycle can be interrupted at any time by pressing START/STOP (STOP): press START/STOP (START) again in order to restart again the cycle.

## 7.9. Freezing





### 7.9.1. Selecting and setting of freezing cycle



Load the machine suitably with the food to be frozen, place the core probe into the food and close the door.

With the appliance on STANDBY press   : the display will show the set point temperature of the room referred to -40°C cycle, in the meantime the icons  and  flash. Use the  and  buttons to edit this value.

Press START/STOP (START) to start the cycle: the display will show the temperature of the room and the icons  and  will remain on. As already explained, once confirmed the cycle, the  device does an automatic identification of probe's insertion (around 2 minutes), at the end of which the cycle will be confirmed or by probe or by time. All this process will be made AUTOMATICALLY.

If the test has a positive result, the device will confirm the temperature controller cycle (probe) and the display will show the temperature of the probe.

Otherwise, if the result is negative, after buzzer's alarm and visual signalling of the flashing icon , the display will show the icon  and the cycle will change in time controlled cycle. Use the  and  buttons to edit this value.

During the visualization of the residual time, it is possible to change the temperature of the room by pressing the buttons   .

You can **DIRECTLY** select the cycle time, bypassing the automatic stage of probe recognition.

With the appliance on STANDBY press TWICE    : the display will show the duration of the cycle **240 min**, in the meantime the icons  and  flash. Use the  and  buttons to edit this value. Then press START/STOP (START) in order to start the cycle.



Once finish the time relative to 240' cycle or once reaches the core temperature of -18°C, the device automatically starts the conservation cycle, -25°C rooms, previously reported by the buzzer's alarm.

On the display will appear the icon .

The cycle can be interrupted at any time by pressing START/STOP (STOP): press START/STOP (START) again in order to restart again the cycle.

## 7.10. Special uses

### 7.10.1. Pre-chilling function or continuous cycle

If the temperature of the food to be chilled is very high (above 65°C) it is advisable to pre-chill it in the following way: press the button  for some seconds, the device will start and the led  will flash. Once reached the set point (-30°C), the led remains on and it will be possible to choose any type of cycle or load the device with the foods you have to

chill/freeze. The new selected cycle will “overwrite” the continuous cycle, without turning off the device previously.

**The continuous cycle is ideal for ice-cream laboratories, as the working cycles are very frequent (HARDERING).**

**It is necessary to have just the room temperature as parameter. Instead, time is not a parameter necessary.**

### 7.10.2. Defrost

The machine evaporator is defrosted by stopping the compressor. It can be **Automatic** or **Manual** and is shown on the display by illumination of the wording “**DEF**” first fixed then, during the drip flashing.

**Automatic** defrost can only take place during the holding period, at intervals of 6 hours with a duration of 15’ and the evaporator temperature does not exceed +8°C.

**Manual** defrosting can be activated when the machine is on STANDBY and the evaporator temperature does not exceed +8°C, by pressing . Because on STANDBY the compressor is already off forced ventilation takes place during Manual defrost, so it is advisable to keep the door open throughout the cycle.

### 7.10.3. Long idle periods

Turn the machine OFF by pressing START/STOP for three seconds, then unplug.

Clean the machine thoroughly (see paragraph 0) and make sure the door is left open at the end of the operation and throughout the idle period.

## 8. MAINTENANCE

### 8.1. Special precautions



**Contact the manufacturer for any anomalies not described in this manual; contact the manufacturer also for any doubts during the maintenance operations described herein. Maintenance carried out by unauthorized personnel may damage the appliance and expose the operator to serious hazards.**



**Maintenance carried out by unauthorized personnel is considered tampering with the appliance and therefore nulls the warranty and relieves the manufacturer of any responsibility.**



**Any routine or extraordinary maintenance operation that requires the electric box to be opened or the machine to be dismantled, even partially, must be carried out only after the appliance has been switched off, ⏻ on the display, and unplugged. Any maintenance operations carried out on a live machine may cause people serious accidents which may also be fatal.**



**The safety devices must be deactivated only by authorized personnel, who will guarantee safety for people and avoid damage to the machine. The safety devices must be carefully activated again after carrying out maintenance.**



**During maintenance or repairs unauthorized persons must keep a safe distance from the appliance.**



**Observe the intervals prescribed or indicated in this manual for making inspections.**



**At the end of maintenance or repairs the appliance can be started only after the specialist engineer has made sure that:**

- **all the work has been fully carried out;**
- **the safety systems are active;**
- **the appliance is working perfectly;**
- **no-one is working on the appliance.**

## 8.2. Routine maintenance

### 8.2.1. Routine maintenance table

Component	Type of operation	Timing	Responsibility	Method
Chamber	Cleaning	When needed	Appliance operator	See section 8.2.2
External part	Cleaning	When needed	Appliance operator	See section 8.2.3
Condenser	Cleaning	Every 30 days	Appliance operator	See section 8.2.4
Core probe	Cleaning	Every cycle	Appliance operator	See section 8.2.5

**Table 3. Routine maintenance table**

### 8.2.2. Cleaning the chamber

Carry out this operation whenever necessary.

#### **Appliance status:**

ON/OFF button on OFF (⏻ on the display) and power supply plug disconnected from the mains.

#### **Authorized personnel:**

Appliance operator.

#### **Method:**

Clean very carefully the internal part of the chamber, the door closure surface (ref. 1 fig. 8) and gasket (ref. 2 fig. 8), using a non-abrasive sponge soaked in neutral detergent. Rinse with a sponge soaked in water and dry with a clean cloth.

Proper cleaning of the inside of the appliance prevents the formation of bad odour which could affect the end product negatively.



***Use exclusively water and non-abrasive neutral detergent for cleaning. The use of different products could damage the surface of the appliance and compromise the quality and healthiness of the product being processed.***

***Do not use abrasive sponges.***



***When cleaning do not use cloths that leave lint.***





**Do not use water jets to clean the appliance.**

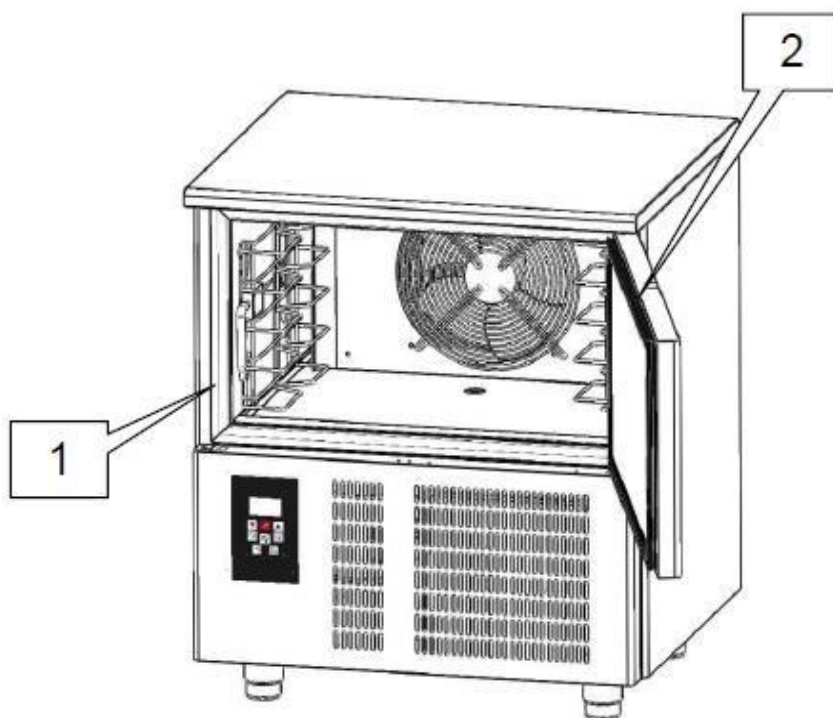

**Figure 8. Door closure and gasket**

### **8.2.3. Cleaning the outside of the appliance**

Carry out this operation whenever necessary.

#### **Appliance status:**

ON/OFF button on OFF (⏻ on the display) and power supply plug disconnected from the mains.

#### **Authorized personnel:**

Appliance operator.

#### **Method:**

Clean the outer surface of the appliance (steel base and panelling), using a non-abrasive sponge soaked in neutral detergent. Rinse with a sponge soaked in water and dry with a clean cloth.



***Use exclusively water and non-abrasive neutral detergent for cleaning. The use of different products could damage the surface of the appliance and compromise the quality and healthiness of the product being processed.***

***Do not use abrasive sponges.***



***When cleaning do not use cloths that leave lint.***

#### **8.2.4. Cleaning the condenser**

Carry out this operation every 30 days.

##### **Appliance status:**

ON/OFF button on OFF (⏻ on the display) and power supply plug disconnected from the mains.

##### **Authorized personnel:**

Appliance operator.

##### **Method:**

To ensure that the appliance works properly and efficiently, the air condenser (ref. 1 fig. 9) must be kept clean so that the air can circulate freely. This operation should be carried out every 30 days. Remove the control panel by loosening the screws (ref. 2 and 3 fig. 9). Clean with a non-metal brush to remove all the dust and fluff from the fins. It is advisable to use a vacuum cleaner so that dust does not float in the air. If there are greasy deposits, eliminate with a brush soaked in alcohol.



***DO NOT SCRAPE THE SURFACES WITH POINTED OR ABRASIVE OBJECTS.***

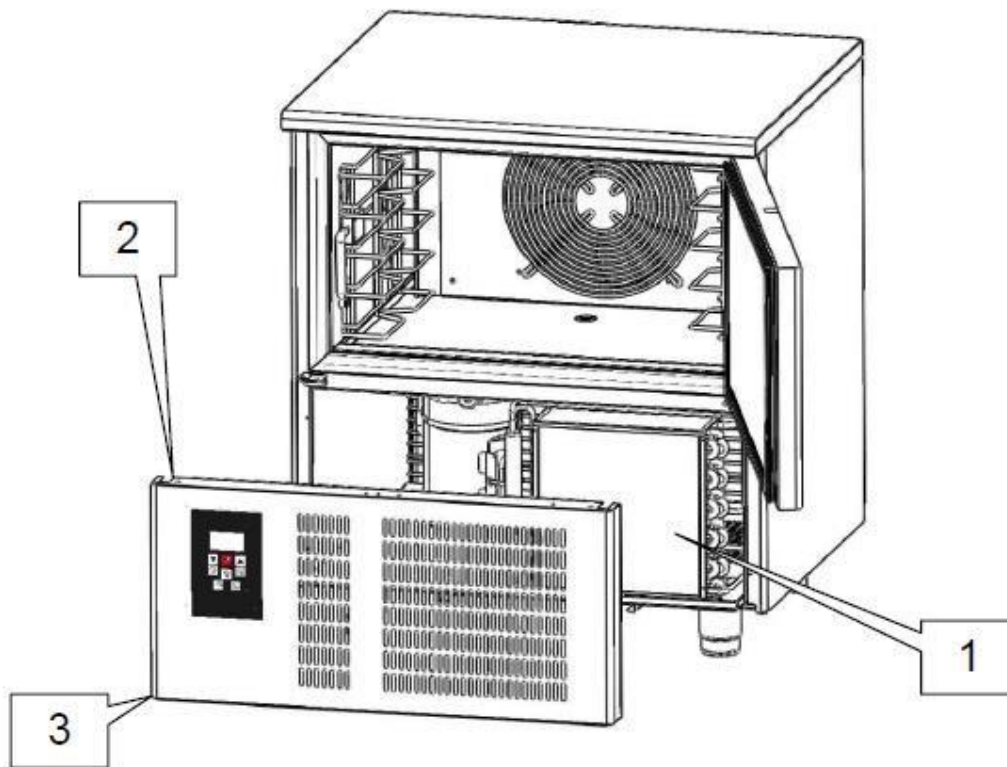

**Figure 9. Air condenser and control panel of the blast chiller**



***The condenser has sharp edges. When carrying out the operations mentioned above, wear safety gloves, goggles, and face masks.***



***Do not clean the equipment using water jets.***

### **8.2.5. Cleaning the core probe**

Carry out this operation at every cycle.

#### **Appliance status:**

ON/OFF button in position "O" (OFF).

#### **Authorized personnel:**

Appliance operator.

## Method:

The core probe (ref. 1 fig. 10) must always be cleaned before a new cycle so as to avoid polluting the product in any way.

Remove all residue by means of a sponge soaked in neutral detergent. Rinse with lots of water and apply a sterilizing product.

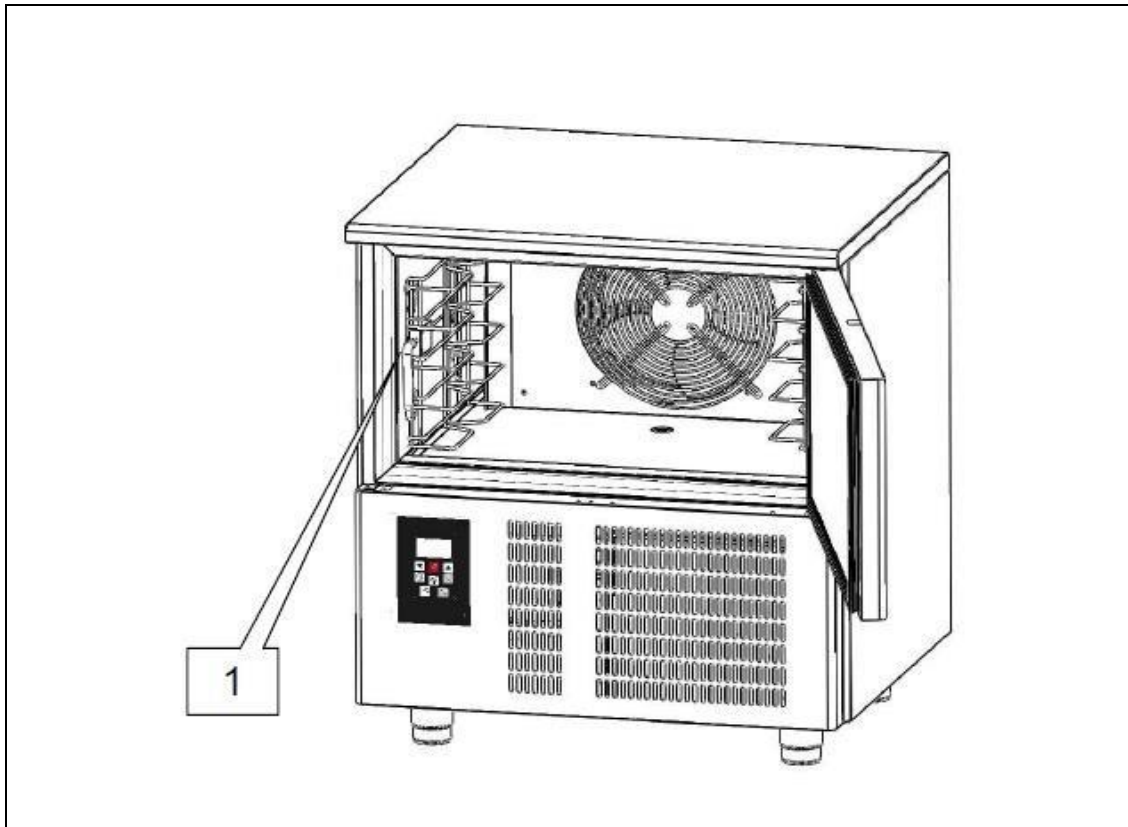

**Figure 10. Blast chiller core probe**



***Do not pull the probe wire; you may damage it.***



***The probe has a very pointed end. During cleaning always wear safety gloves and take the utmost care.***

### 8.3. Extraordinary maintenance

If the appliance needs extraordinary maintenance, or if operating anomalies occur that are not described in this manual, contact the manufacturer.

## 8.4. Operating anomalies and faults

It is important to remember that whatever machine status is, pressing the button START/STOP for 3 seconds turns it OFF.

When any operating anomaly occurs, the buzzer sounds intermittently, and red wording appears on the display. Whatever the reason for the buzzer, it can be silenced by pressing any button.

### 8.4.1. Alarms

Possible alarm warnings on the display are as follows:

- **“ tiME ”** alarm temperature chilling or temperature freezing are not reached within the maximum duration (HACCP). This alarm does not have any effect, it will be just memorized.
- **“ AL ”** alarm minimum temperature. During any kind of cycle, this alarm does not have any effect.
- **“ AH ”** alarm maximum temperature. During any kind of cycle, this alarm does not have any effect.
- **“ HP ”** high pressure switch alarm. On STANDBY it has no effect. During any other work stage, it causes the cycle to stop and go onto STANDBY. Eliminate the cause of the alarm then turn off the machine by pressing START/STOP for 3 seconds, then press START/STOP (START) to re-start. This alarm can be caused by high ambient temperature (above that admitted; see para. 2.4) or a dirty condenser (which must be cleaned as described in para. 8.2.4).
- **“ id ”** door open alarm. This alarm does not have any effect and it will finish by closing the door.

### 8.4.2. Errors

Errors recognized by the electronic controller are:

- **“ Pr 1 ”** chamber probe error. On STANDBY impedes cycle start. On Chilling or Freezing causes the cycle to stop and the machine to go onto STANDBY. During the Holding period the cycle is not interrupted, and the compressor works cyclically to ensure maintenance of the chamber temperature. Check probe connection and replace if necessary.
- **“ Pr 2 ”** core probe error. On STANDBY impedes the start of a temperature-controlled cycle. On temperature-controlled Chilling or Freezing causes the machine to go to a time-controlled cycle. During the Holding period it has no effect. Check probe connection and replace if necessary.
- **“ Pr 3 ”** evaporator probe error. On STANDBY, Chilling or Freezing and during Holding it has no effect. If defrost is taking place it will end by time-out.

## 9. DISMANTLING



***Contact the manufacturer to dismantle the appliance in any way.***

## 10. DISPOSAL

### 10.1. Disposal method

#### Appliance status:

- electronic circuit board in position "O" (OFF).
- power supply plug disconnected from the mains.

#### Method:

The appliance is made of ferrous materials, electronic components and plastics. If it needs to be disposed of, separate the various components according to the material of which they are made, to simplify separate waste collection or re-use of the parts. The appliance must be disposed of separately from urban waste.

No special instructions apply to the dismantled appliance. Dispose of it through the special operators or return to the dealer, if the law provides for this (also see "Information to users regarding waste disposal in the European Union" below).

For disposal consult the laws applicable in the country where the appliance is used (also see "Information to users regarding waste disposal in the European Union" below).



**TAKE CARE: THE APPLIANCE CONTAINS REFRIGERANT GAS THAT MUST BE CONTROLLED AND RECOVERED ACCORDING TO THE REGULATIONS OF THE COUNTRY IN WHICH DISPOSAL WILL TAKE PLACE.**



**Consult the fitter for any dismantling requirements.**

### INFORMATION TO USERS REGARDING WASTE DISPOSAL IN THE EUROPEAN UNION



The symbol of a crossed waste bin on the appliance indicates that at the end of its working life the product must be collected separately from other waste.

Therefore, at the end of the product's working life the user must take it to a suitable centre for the collection of electronic and electrical waste or return it to a dealer when purchasing a new appliance of the same type.

Suitable separate waste collection of unwanted appliances and their forwarding to treatment, recovery and environmentally friendly disposal makes it possible to avoid

potential negative effects on the environment and human health and assists recycling and recovery of materials.

Unauthorized disposal of the product by the user is punished by the application of fines established by the countries in which the appliance is disposed of.



## **11. SPARE PARTS**

### **11.1. Ordering spare parts**

To order spare parts, contact the manufacturer or the authorized dealer.